

Spinner Flowmeter

Titan Industries

8169-16852FM212-05-0X-A

DescriptionStand Alone Flowmeter Assembly, Trim Kit, 5 P Spinner

Part Number8169-16852FM168-05-0X-A
Tool Cage Diameter 1 11/16" (4.29 cm)
Tool Length23.48" (59.64 cm)
Weight 8 lbs. (3.62 kg)

Measure Point:

Bottom of Tool to Center of Impeller2.75" (6.99 cm)

Part Number8169-16852FM212-05-0X-A
Tool Cage Diameter2 1/8" (5.40 cm)
Tool Length*currently unknown 07-27-07*
Weight*currently unknown 07-27-07*

Part Number8169-16852FM300-05-0X-A
Tool Cage Diameter 3" (7.62 cm)
Tool Length23.63" (60.02 cm)
Weight9 lbs. (4.08 kg)

Measure Point:

Bottom of Tool to Center of Impeller approx 3.9" (9.9 cm)

Dimensions and Ratings:

Temperature Rating350° F (204.4° C)
Maximum Pressure Rating 15,000 PSI (103 MPa)
Tool Body Diameter without Cage1 11/16" (4.29 cm)
Recommended Logging Speed30-40 Ft (9.1 M)/ Min
Maximum Logging Speed60 Ft (18.3 M)/ Min
Operating Voltage120 VDC pos.
Operating Current30 mA

Measure Point: Top of Tool to Center of Impeller20.73"

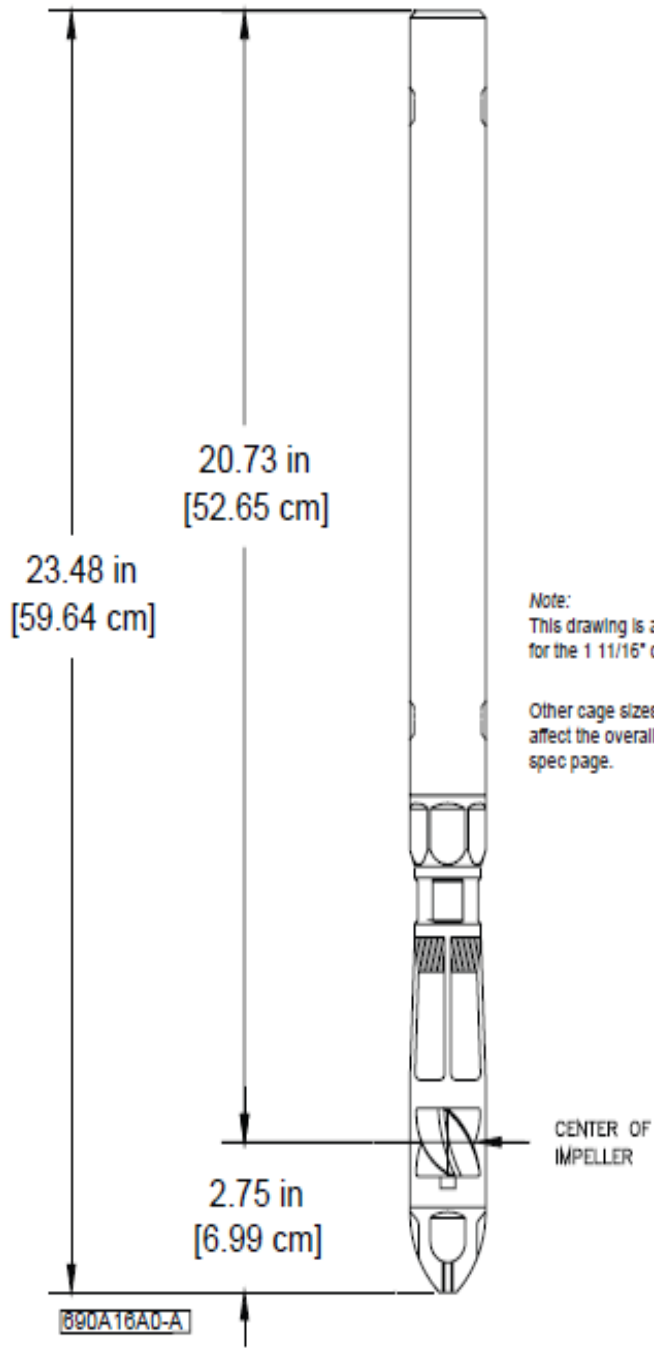

Note:
This drawing is a representation
for the 1 11/16" only.

Other cage sizes available which
affect the overall length, see
spec page.